

Art. XM2922

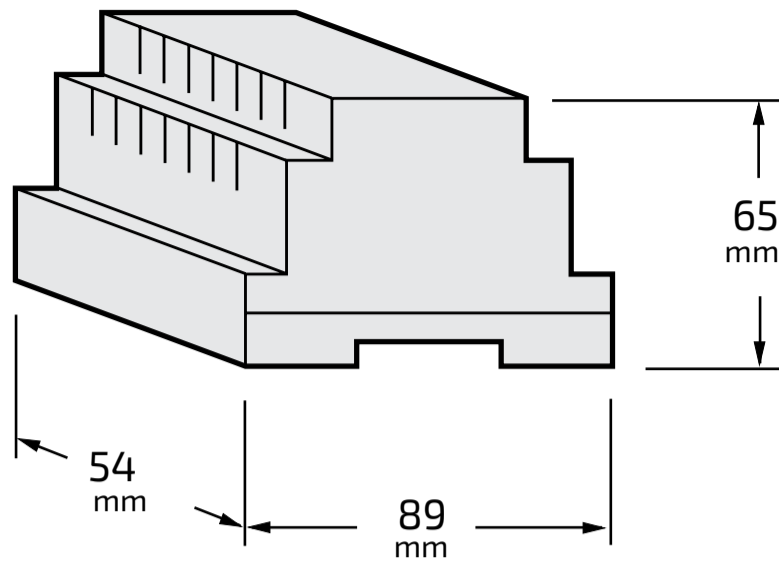

IT Driver di linea per sistema DUO

Articolo in grado di accoppiare un qualsiasi alimentatore ad un impianto DUO.

Dati tecnici

Alimentazione:	36Vcc±1
Corrente massima d'uscita:	1 A
Temperatura funzionamento:	0 ÷ +40°C
Umidità massima:	90%RH
Contenitore:	DIN 3 moduli A

Morsetti

IN/IN Ingresso alimentazione +36Vcc+/-1
LP/LP Collegamento alla linea digitale DUO

Ponticello di chiusura / apertura dell'impedenza di linea

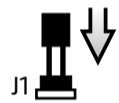

ponticello **J1** inserito = chiusura su impedenza di linea 100 Ω

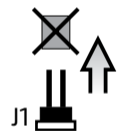

ponticello **J1** tolto = linea aperta

EN Line Driver for DUO system

The item is able to couple any power supply to a DUO system.

Technical data

Power supply:	36Vdc±1
Maximum load:	1 A
Operating temperature:	0 ÷ + 40 °C
Maximum humidity:	90% RH
Housing:	3 module A DIN

Terminals

IN/IN Power supply input +36Vdc+/-1
LP/LP Line output

Jumper for close or open line impedance

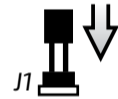

J1 jumper inserted = closing on 100Ω line impedance

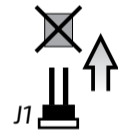

J1 jumper removed = open line

FR Driver de ligne pour système DUO

Article apte à accoupler une alimentation quelconque aux une installation DUO.

Données techniques

Alimentation:	36Vcc±1
Maxime courante de sortie:	1 A
Température fonctionnement:	0 ÷ +40°C
Humidité maximum:	90%RH
Boîtier:	DIN 3 modules A

Bornes

IN/IN Entrée alimentation +36Vcc+/-1
LP/LP Branchement à la ligne

Pontet pour fermer/ouvrir l'impédance de ligne

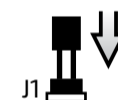

J1 pontet inséré = fermeture sur l'impédance de ligne de 100 Ω



J1 pontet enlevé = ligne ouverte

IT Collegamento del modulo XM2922 al distributore di linea DV2420

EN Connection of the module XM2922 to the line distributor DV2420

FR Liaison du module XM2922 au distributeur de ligne DV2420

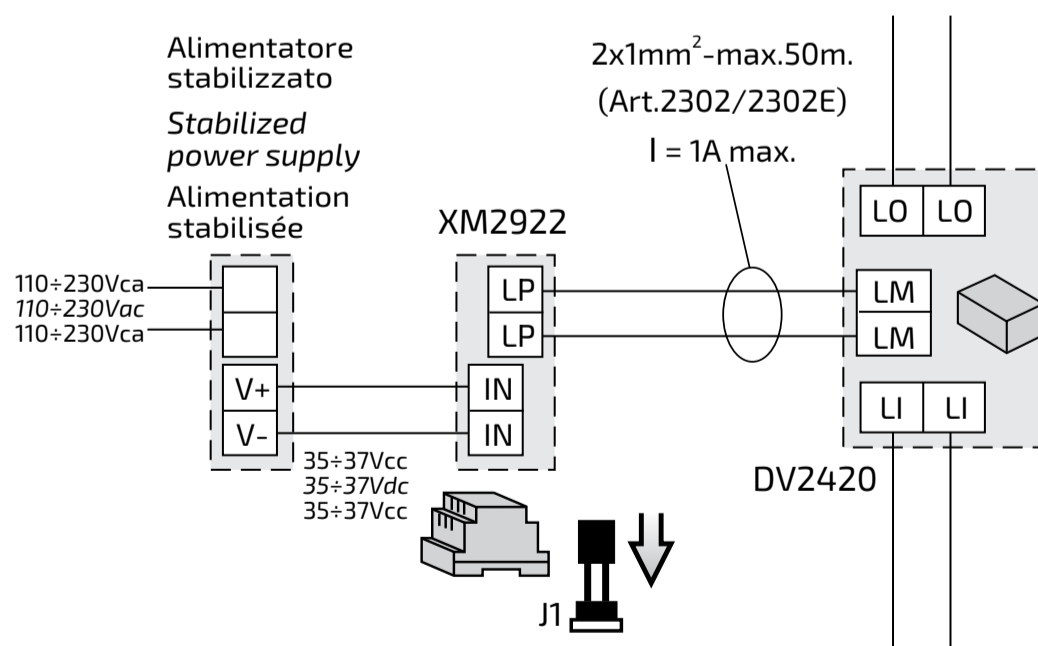

Directive 2012/19/EU (WEEE-RAEE)

Smaltire il dispositivo secondo quanto prescritto dalle norme per la tutela dell'ambiente.
 Dispose of the device in accordance with environmental regulations.
 Écouler le dispositif selon tout ce qu'a été prescrit par les règles pour la tutelle du milieu.
 Eliminar el aparato según cuánto prescrito por las normas por la tutela del entorno.
 Disponha do dispositivo conforme regulamentos ambientais.
 Werden Sie das Gerät in Übereinstimmung mit Umweltregulierungen los.

ACI srl Farfisa Intercoms

Via E. Vanoni, 3 • 60027 Osimo (AN) • Italy
 Tel: +39 071 7202038 (r.a.) • Fax: +39 071 7202037
 e-mail: info@farfisa.com • www.farfisa.com

Mi2485/1
 Cod. M527052210

La ACI Srl Farfisa Intercoms si riserva il diritto di modificare in qualsiasi momento i prodotti qui illustrati.
 ACI Srl Farfisa Intercoms reserves the right to modify the products illustrated at any time.
 La ACI Srl Farfisa Intercoms se réserve le droit de modifier à tous moments les produits illustrés.

ACI Srl Farfisa intercoms se reserva el derecho de modificar en cualquier momento los productos ilustrados aquí.
 E' riservata a ACI Srl Farfisa intercoms o direito de modificar a qualquer momento os produtos aqui ilustrados.
 Änderungen vorbehalten.